

Project	
Date	
Prepared By	
Model #	LTF2X2WSCCT1

Specifications

ELECTRICAL

Watts: 20, 25 or 30

Voltage: 120-277VAC

Power Factor: 0.9

Operating Temp. Range:
-20°C (-4°F) to 50°C (122°F)

LIGHT

Lumens:

2500, 3125 or 3750

Color Temperature:

3500K, 4000K, 5000K

CRI: 82

AGENCY APPROVALS

DLC® Premium: Yes

UL: Yes

FCC: Yes

PRODUCT DETAILS

Lens: Acrylic

Warranty: 5 years

Fixture

Rated Life: 50,000 hours

Lumen Maintenance:

L70 at 100,000 hrs (70°C)

Weight: 9.91 LBS

Dimensions:

23.78" L x 23.78" W x 2.76" H

LED Troffer 2x2

Color and Wattage Selectable

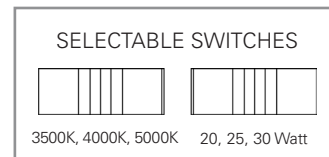

ORDER CODE:

11604

MODEL NUMBER:

LTF2X2WSCCT1

COLOR SELECTABLE:

3500K / 4000K / 5000K

LUMEN LEVEL:

2500 lumens - 20 watts

3125 lumens - 25 watts

3750 lumens - 30 watts

DLC® PRODUCT ID:

S-X7C2FV

REBATE AVAILABILITY*

PRODUCT DESCRIPTION

EarthTronics LED Troffer fixture features the architectural basket lens design within a slim profile fixture that easily installs in 2x2 ceiling grid systems. Select from 3500K, 4000K or 5000K color temperatures as well as 2500, 3125 or 3750 lumen levels. The basket lens is held securely in place and provides even light distribution. The fixture is complete with T-bar hanger clips satisfying earthquake requirements and providing a secure installation. The solid state driver delivers long life without the flicker associated with fluorescent lighting products. These Troffers feature 120-277V dual voltage operation. They are equipped standard with a 0 - 10 volt continuous dimming driver with a dimming range capability of 10% to 100%. Ideal for construction, renovation and retrofit commercial applications. An optional factory installed microwave occupancy sensor with timed delay and step dimming functions is available. A remote control is available to easily adjust sensor settings. DLC® Premium listed.

PRODUCT FEATURES

- + Color selectable: 3500K, 4000K, 5000K
- + Wattage selectable: 20, 25, 30
- + Standard 120-277V
- + 0-10V continuous dimming driver
- + Dimming range of 10% to 100%
- + DLC® Technical Requirement 5.1
- + Microwave occupancy sensor available
- + Basket lens is securely mounted
- + Easily installs in drop ceiling T-bar grids
- + Factory preset to maximum wattage, 4000K
- + L70 at 100,000 hours (70°C)

APPLICATIONS

- + Office
- + Healthcare Facilities
- + New Construction
- + Commercial
- + Industrial

Please consult installation instructions for proper application and use of this fixture.

*Rebate availability access it here: www.earthtronics.com/rebate-finder

PRODUCT DIMENSIONS

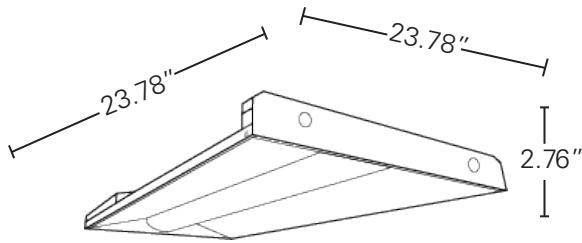

PACKAGE DETAILS

Carton Qty: 2

Dimensions:

24.17" Length x 24" Width x 4.61" Height

Weight: 15.12 LBS

UPC: 840791116043

LIGHT DISTRIBUTION CURVE

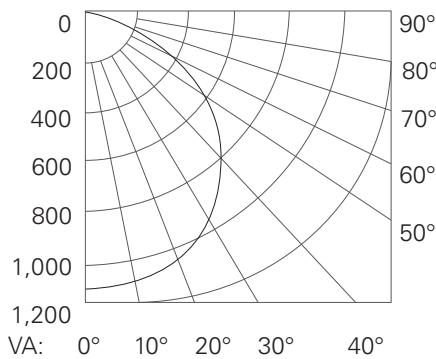

Average Illuminance: 49 fc

Number of Luminaires: 10

Workplane Height: 2.5 ft

LIGHTING LAYOUT

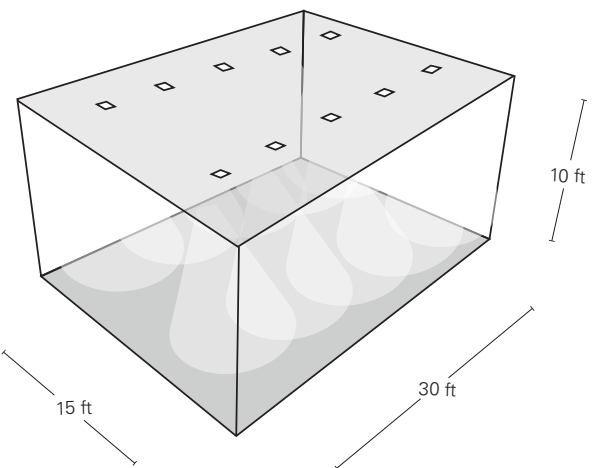

OPTIONAL ACCESSORIES

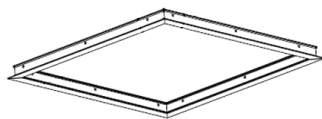
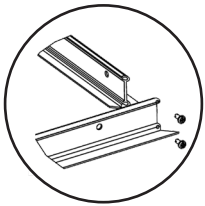

Recessed Drywall Kit
Order Code: 11101



External Emergency Backup Unit
Order Code: 11469



Microwave Sensor
Order Code: 11607



Sensor Remote
Order Code: 11653

Easily access our DLC qualified products with rebates in your area.

ACCESS IT HERE: [Rebate Finder - LEDTroffer](#)

www.earthtronics.com/rebate-finder/catalog/

